

Analog input module

AI

M1-33B

2 analog inputs (± 20 mVDC)

- ▶ 16-bit analog converters
- ▶ Optically and electrically isolated
 - Each channel has an electrically isolated analog ground
 - Each channel is individually optically isolated
- ▶ Each channel has individually configurable digital filtering

General specifications

Inputs per module	2 (differential ended)
Input type	Voltage, ± 20 mVDC
Connector	Removable
Connection type	Screw terminal
Terminal wire size	14 – 22 AWG
Test point	All connections
Module size	1 controller bay

Bus power required (5 VDC)	0.2 mA
Isolation rating	500 VDC
Operating temperature	
Horizontal installation ¹	0 – 50°C
Vertical installation ¹	0 – 45°C
Storage temperature	-25 – 85°C
Humidity	5 – 95% non-condensing
5100 equivalent part number	V

1. Refer to the applicable controller datasheet for proper mounting instructions.

Performance specifications

Parameter	Value
Input range	-20 mV to 20 mV
Input resolution	16-bit
Input resistance	
+Ain to -Ain	$10^{12} \Omega$
+Ain to ACOM	$10^{12} \Omega$
-Ain to ACOM	1.5 M Ω
Max input voltage	± 32 VDC

Parameter	Value
Full range calibration error ^{1,2}	0.013% of range
Offset calibration error at 0 V ^{1,2}	0.013% of range
Linearity error (full range) ^{1,2}	0.037% of range
Digital input filter size (settable)	1-255 samples
Digital input filter rate	5 msec
Output slew rate (max)	10 V/ μ sec
Controller engineering units (channel configurable)	20 mVDC = 10,000 or 20 mVDC = 20,000 or 20 mVDC = 10,000,000

1. Errors are at 25°C.
2. Errors are double across full ambient temperature range of 0 – 50°C.

Analog input module

AI

M1-33B

Typical Application

Analog Input Application

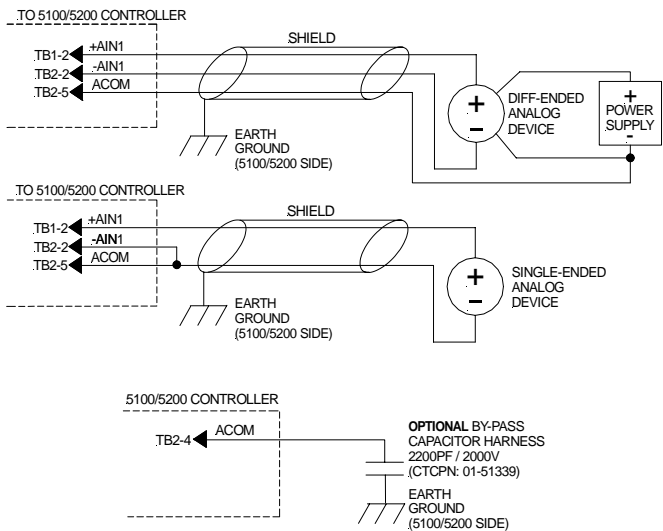

	5100	5200
Minimum hardware revision	E	E
Minimum firmware revision	1.07	1.07
Minimum operating system revision	4.04.12	5.06
Document number: 950-513306-0001		

Connections

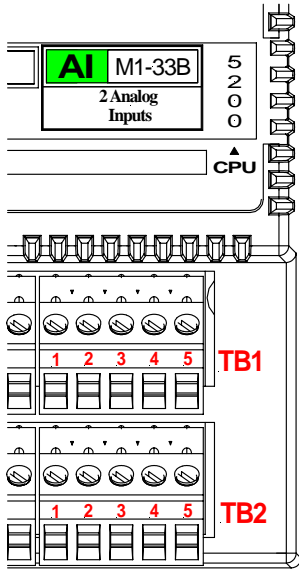

I/O Terminations

TB1-1	VS_OUT
TB1-2	+Ain #1
TB1-3	+Ain #2
TB1-4	N/C
TB1-5	N/C
TB2-1	VS_RTN
TB2-2	-Ain #1
TB2-3	-Ain #2
TB2-4	ACOM
TB2-5	ACOM

Notes

- Shield grounds must be terminated on the controller side of the cable.
- When an analog device is powered via an external power source, it may be necessary to tie the ground of this power source to the module's analog common (ACOM) to limit common mode voltages.
- For register and programming information, refer to the appropriate controller Applications Guide.
- The information and illustrations contained herein are the property of Control Technology Corporation and are subject to change without notice. Data based on VS = 24VDC @ 25°C unless otherwise noted. For additional information and/or updates visit www.ctc-control.com.
- VS refers to the voltage supply of the controller.