

Dual axis servo module

SERVO

M1-40A

2 axes servo controller with high speed registration

- ▶ High-speed, 32-bit motion processor
- ▶ Optically and electrically isolated
 - Each channel has an electrically isolated analog ground
 - Each channel is individually optically isolated
- ▶ Precision 16-bit command signal
- ▶ Updates both position loops in 500 μ sec
- ▶ < 1 μ sec registration response

General specifications

Connector	Removable
Connection type	Screw terminal
Terminal wire size	14 – 22 AWG
Test point	All connections
Module size	2 controller bays

Isolation rating	500 VDC
Operating temperature	
Horizontal installation ¹	0 – 50°C
Vertical installation ¹	0 – 45°C
Storage temperature	-25 – 85°C
Humidity	5 – 95% non-condensing
5100 equivalent part number	SS

1. Refer to the applicable controller datasheet for proper mounting instructions.

Performance specifications

Parameter	Value
Position range	$\pm 2,147,483,647$ counts
Velocity range	± 6 M counts/sec
Position resolution	± 1 count
Velocity resolution	± 1 count/sec
Max acceleration	130 M counts/sec ²
Position loop update	500 μ sec/2 axes
Command type	Analog torque or velocity
Command signal voltage	Bipolar single-ended ± 10 V (5mA max)
Command resolution	16-bit
Encoder feedback type	5 V - differential quadrature
Max input voltage	6 VDC

Parameter	Value
Encoder Turn ON threshold	3.0 VDC
Encoder Turn OFF threshold	0.125 VDC
Encoder termination resistor	220 Ω (10%)
Encoder index signal	5 VDC single-ended
Registration input type	VDC sourcing
Registration response	<1 μ sec
Registration Turn ON threshold	0.53* VS
Registration Turn OFF threshold	0.32* VS
Max registration voltage	VS
Max ON registration current	2.6 mA DC
Registration input resistance to VS_RTN	10 K Ω (10%)

Dual axis servo module

SERVO

M1-40A

Typical Applications

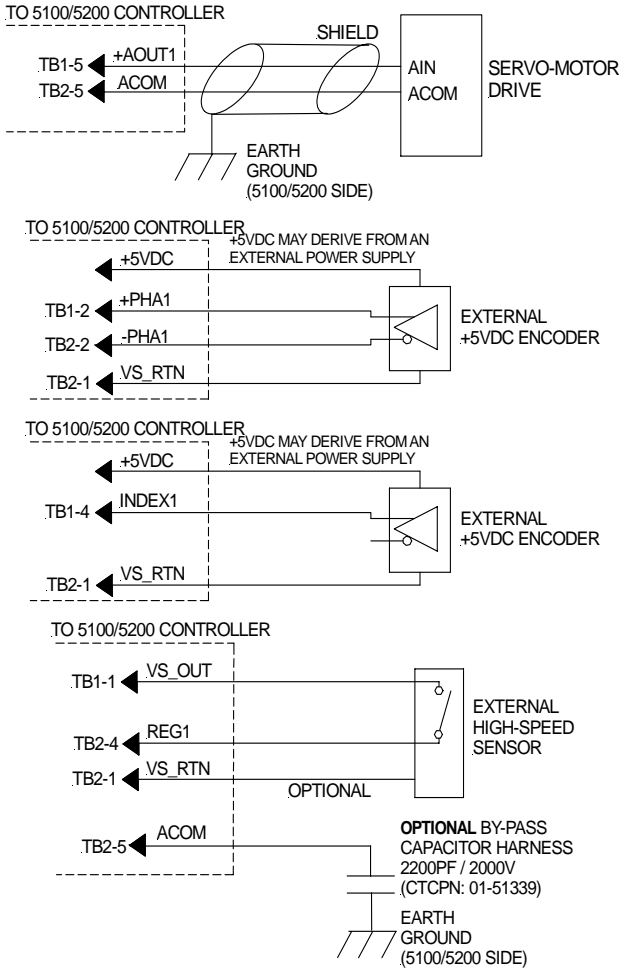

	5100	5200
Minimum hardware revision	A, B	A, B
Minimum firmware revision	4.18	4.18
Minimum operating system revision	4.04	5.06
Document number: 950-514002-0003		

Notes

1. Shields must be terminated on the controller side of the cable.
2. External power supply commons must be tied to the controller's supply voltage return (VS_RTN) and / or analog common (ACOM).
3. For register and programming information, refer to the M1-40A Applications Guide.
4. The information and illustrations contained herein are the property of Control Technology Corporation and are subject to change without notice. Data based on VS = 24VDC @ 25°C unless otherwise noted. For additional information and/or updates visit www.ctc-control.com.
5. VS refers to the voltage supply of the controller.

Connections

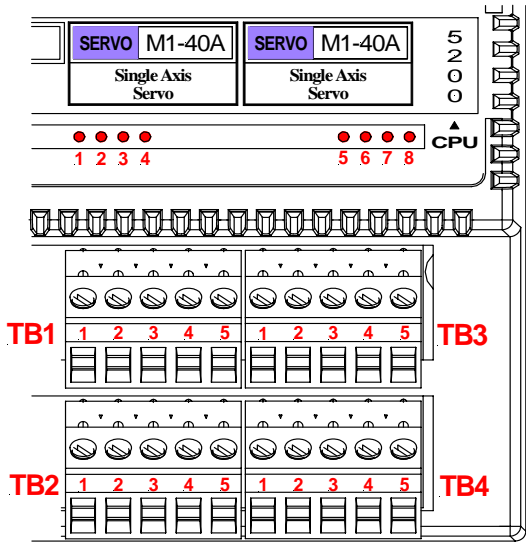

I/O Terminations

Axis 1			Axis 2		
TB1-1		VS_OUT	TB3-1		VS_OUT
TB1-2	LED1	+PHA1	TB3-2	LED5	+PHA2
TB1-3	LED2	+PHB1	TB3-3	LED6	+PHB2
TB1-4	LED3	INDEX1	TB3-4	LED7	INDEX2
TB1-5		+AOUT1	TB3-5		+AOUT2
TB2-1		VS_RTN	TB4-1		VS_RTN
TB2-2		-PHA1	TB4-2		-PHA2
TB2-3		-PHB1	TB4-3		-PHB2
TB2-4	LED4	REG1	TB4-4	LED8	REG2
TB2-5		ACOM	TB4-5		ACOM