

Intelligent digital input/output module

DI/O

M3-10A

DI/O

M3-20A

M3-10A: 16 sinking inputs (+VS VDC), 16 sinking outputs (+VS VDC)

M3-20A: 16 smart digital inputs (+VS VDC), 16 digital outputs (+VS VDC)

- ▶ Wide input hysteresis voltage for solid switch points
- ▶ Individual channel status LEDs
- ▶ Optically isolated
- ▶ Open collector NPN to the controller's voltage supply return
- ▶ High current: 500 mA per output/3 A per module

General specifications

Inputs per module	16
Input type	VDC sinking
Outputs per module	16
Output type	Sinking (NPN open collector)
Connection	Removable terminal block
Connection type	Tension clamp
Terminal block part number	069-621010
Terminal wire size (UL 1059)	18 - 22 AWG
Test point	All connections
Status indicator	One LED per channel
Module size	1 rack slot (0.75"/19 mm)
Isolation rating	500 VDC
Operating temperature	
Horizontal installation	0 - 50°C
Vertical installation	0 - 45°C
Storage temperature	-25 - 85°C
Humidity	5 - 95% non-condensing

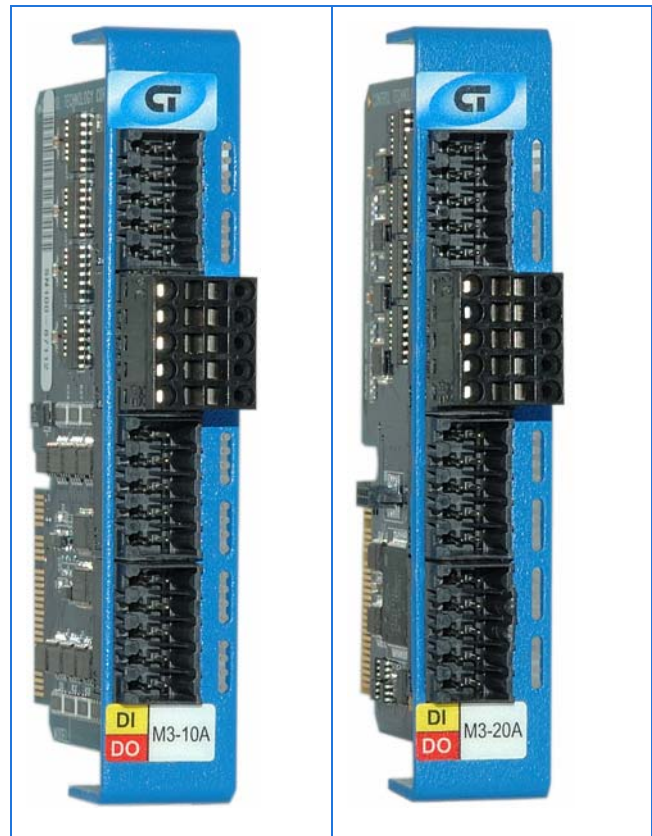

Actual size

Minimum hardware revision	B
Minimum firmware revision	1.02
Minimum operating system revision	5.00.90
Documentation number: 950-531001-004	

Intelligent digital input/output module

DI/O

M3-10A

DI/O

M3-20A

Performance specifications

Inputs

Parameter	Value
Input voltage (VS)	10 – 32 VDC
Max voltage	32 VDC
Nominal voltage (VN)	24 VDC
Turn ON threshold	0.46 * VS
Turn OFF threshold	0.12 * VS
Min hysteresis voltage	0.17 * VS
Min input current	2.6 mA @ 24 VDC
Input resistance to VDC RTN	10 K Ω \pm 10%
Min ON current	1.6 mA
Max OFF current	0.3 mA
Hardware filter	< 1 msec

Outputs

Parameter	Value
Nominal voltage (VN)	VS
Max OFF voltage	Open collector
Max ON voltage @:	
50 mA	0.9 VDC
500 mA	1.4 VDC
Max channel current	500 mA
Max module current	3 ADC
Max controller current	8 ADC
Max leak current/channel	200 μ ADC

Smart mode features

- Eight high-speed counter inputs (DIN 1 – 8 or DIN9 – 16)
- Counting max frequency 12 KHz⁴
- Eight hardware counter resets (DIN 9 – 16 or DIN1 – 8)
- Eight setpoint outputs (DO 1 – 8)
- Eight PWM outputs (DO9 – 16)
- PWM max frequency 12 KHz⁴

Notes

1. Smart mode is not available on the M3-10A module.
2. In the OFF state, the outputs are pulled internally high to VDC RTN via a 10 K Ω series resistor with an LED.
3. Smart mode features are controlled by CTC's QuickBuilder software on a point-by-point basis. When smart features are not enabled, inputs and outputs retain their default features. Smart mode features can be set up by direct register settings; refer to *Doc. No. 951-530006: Model 5300 Quick Reference Register Guide* for more information.
4. Maximum frequency of 12 KHz is valid if only counter inputs or only PWM outputs are enabled. If both high-speed counters and PWM are enabled, max frequency is 6 KHz.
5. Special build options are available for simple stepper control. Contact sales at CTC for further information.
6. The M3-20A module allows users to individually select smart mode or default operation for each I/O point.
7. The information and illustrations contained herein are the property of Control Technology Corporation and are subject to change without notice. Data based on VS = 24 VDC @ 25°C unless otherwise noted. For additional information and/or updates, visit www.ctc-control.com. Copyright © 2007 Control Technology Corp. All Rights Reserved.

Intelligent digital input/output module

DI/O

M3-10A

DI/O

M3-20A

M3-10A: 16 sinking inputs (+VS VDC), 16 sinking outputs (+VS VDC)

M3-20A: 16 smart digital inputs (+VS VDC), 16 digital outputs (+VS VDC)

Terminal block connections

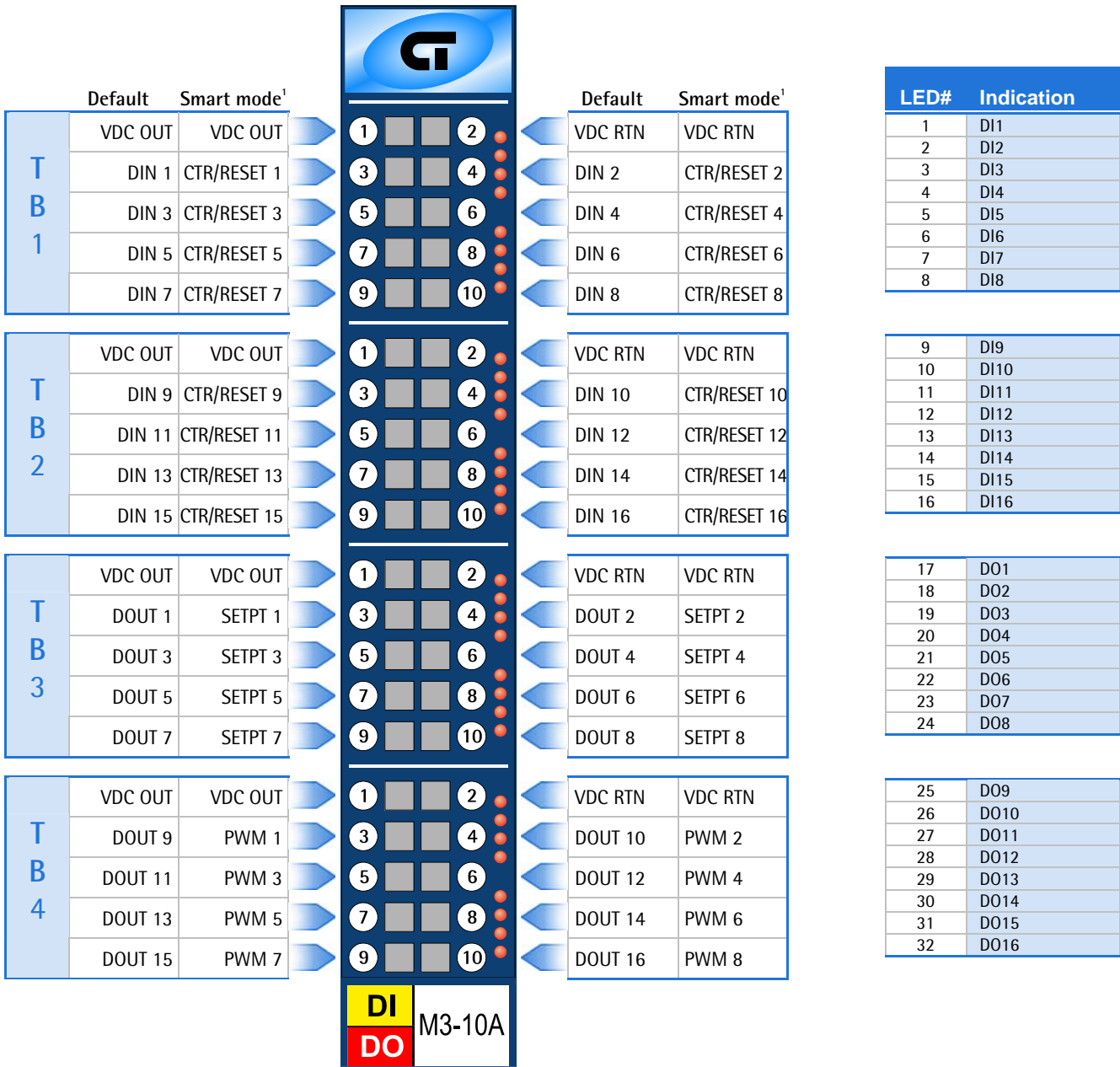

Note

- Smart mode is not available on the M3-10A module.
- If TB1 is set up as counters, TB2 will be resets and vice versa.

Intelligent digital input/output module

DI/O

M3-10A

DI/O

M3-20A

Application information

Typical input application

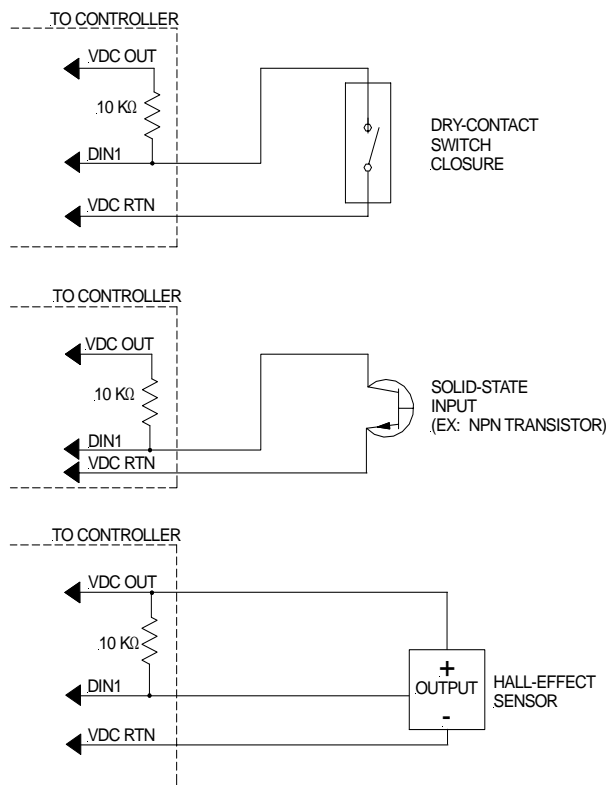

Typical output application

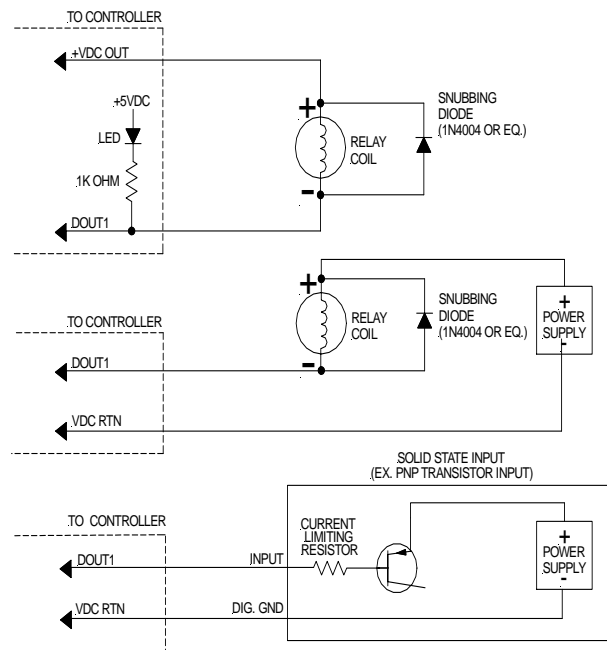

- For applications using externally powered devices (output applications #2 and #3 above), the M3-10A module requires a minimum hardware version of B009 and the M3-20A module requires a minimum hardware version of B003.

Notes

- When a digital device is powered via an external power source, it may be necessary to tie the ground of this power source to the controller's voltage supply ground (VDC RTN).
- For register and programming information, refer to the appropriate controller Applications Guide.
- The information and illustrations contained herein are the property of Control Technology Corporation and are subject to change without notice. Data based on $V_S = 24 \text{ VDC} @ 25^\circ\text{C}$ unless otherwise noted. For additional information and/or updates, visit www.ctc-control.com.
- Observe proper current limiting with transistor loads.
- Use high-speed diode or equivalent to limit inductive load kicks.
- $VDC \text{ OUT} = V_S(\text{DC voltage supplied to the controller's power supply})$.