

## Intelligent digital input/output module

DI/O

M3-10B

DI/O

M3-20C

**M3-10B:** 16 sinking inputs (+5 VDC), 16 sinking outputs (+5 VDC)

**M3-20C:** 16 smart digital inputs (+5 VDC), 16 digital outputs (+5 VDC)

- ▶ Wide input hysteresis voltage for solid switch points
- ▶ Individual channel status LEDs
- ▶ Optically isolated
- ▶ Open collector NPN to the controller's voltage supply return
- ▶ High current: 500 mA per output/3 A per module

### General specifications

|                              |                              |
|------------------------------|------------------------------|
| Inputs per module            | 16                           |
| Input type                   | VDC sinking                  |
| Outputs per module           | 16                           |
| Output type                  | Sinking (NPN open collector) |
| Connection                   | Removable terminal block     |
| Connection type              | Tension clamp                |
| Terminal block part number   | 069-621010                   |
| Terminal wire size (UL 1059) | 18 - 22 AWG                  |
| Test point                   | All connections              |
| Status indicator             | One LED per channel          |
| Module size                  | 1 rack slot (0.75"/19 mm)    |
| Isolation rating             | 500 VDC                      |
| Operating temperature        |                              |
| Horizontal installation      | 0 - 50°C                     |
| Vertical installation        | 0 - 45°C                     |
| Storage temperature          | -25 - 85°C                   |
| Humidity                     | 5 - 95% non-condensing       |



Actual size

|                                      |         |
|--------------------------------------|---------|
| Minimum hardware revision            | B       |
| Minimum firmware revision            | 1.02    |
| Minimum operating system revision    | 5.00.90 |
| Documentation number: 950-531002-003 |         |

## Intelligent digital input/output module

DI/O

M3-10B

DI/O

M3-20C

## Performance specifications

### Inputs

| Parameter                   | Value                  |
|-----------------------------|------------------------|
| Input voltage (VS)          | 4.5 – 5.5 VDC          |
| Max voltage                 | 32 VDC                 |
| Nominal voltage (VN)        | 5 VDC                  |
| Turn ON threshold           | 4.0 VDC                |
| Turn OFF threshold          | 1.0 VDC                |
| Min hysteresis voltage      | 2.5 VDC                |
| Min input current           | 5.5 mA @ 0 VDC         |
| Input resistance to VDC RTN | 1 K $\Omega$ $\pm$ 10% |
| Min ON current              | 5.4 mA                 |
| Max OFF current             | 1.1 mA                 |
| Hardware filter             | < 1 msec               |

### Outputs

| Parameter                | Value          |
|--------------------------|----------------|
| Nominal voltage (VN)     | VS             |
| Max OFF voltage          | Open collector |
| Max ON voltage @:        |                |
| 50 mA                    | 0.9 VDC        |
| 500 mA                   | 1.4 VDC        |
| Max channel current      | 500 mA         |
| Max module current       | 3 ADC          |
| Max controller current   | 8 ADC          |
| Max leak current/channel | 200 $\mu$ ADC  |

### Smart mode features

- Eight high-speed counter inputs (DIN 1 - 8 or DIN9 - 16)
- Counting max frequency 12 KHz<sup>4</sup>
- Eight hardware counter resets (DIN 9 - 16 or DIN1 - 8)
- Eight setpoint outputs (DO 1 - 8)
- Eight PWM outputs (DO9 - 16)
- PWM max frequency 12 KHz<sup>4</sup>

### Notes

1. Smart mode is not available on the M3-10B module.
2. In the OFF state, the outputs are pulled internally high to +5 VDC via a 1 K $\Omega$  series resistor with an LED.
3. Smart mode features are controlled by CTC's QuickBuilder software on a point-by-point basis. When smart features are not enabled, inputs and outputs retain their default features. Smart mode features can be set up by direct register settings; refer to *Doc. No. 951-530006: Model 5300 Quick Reference Register Guide* for more information.
4. Maximum frequency of 12 KHz is valid if only counter inputs or only PWM outputs are enabled. If both high-speed counters and PWM are enabled, max frequency is 6 KHz.
5. The information and illustrations contained herein are the property of Control Technology Corporation and are subject to change without notice. Data based on VS = 24 VDC @ 25°C unless otherwise noted. For additional information and/or updates, visit [www.ctc-control.com](http://www.ctc-control.com). Copyright © 2007 Control Technology Corp. All Rights Reserved.

# Intelligent digital input/output module

DI/O

M3-10B

DI/O

M3-20C

M3-10B: 16 sinking inputs (+5 VDC), 16 sinking outputs (+5 VDC)

M3-20C: 16 smart digital inputs (+5 VDC), 16 digital outputs (+5 VDC)

## Terminal block connections

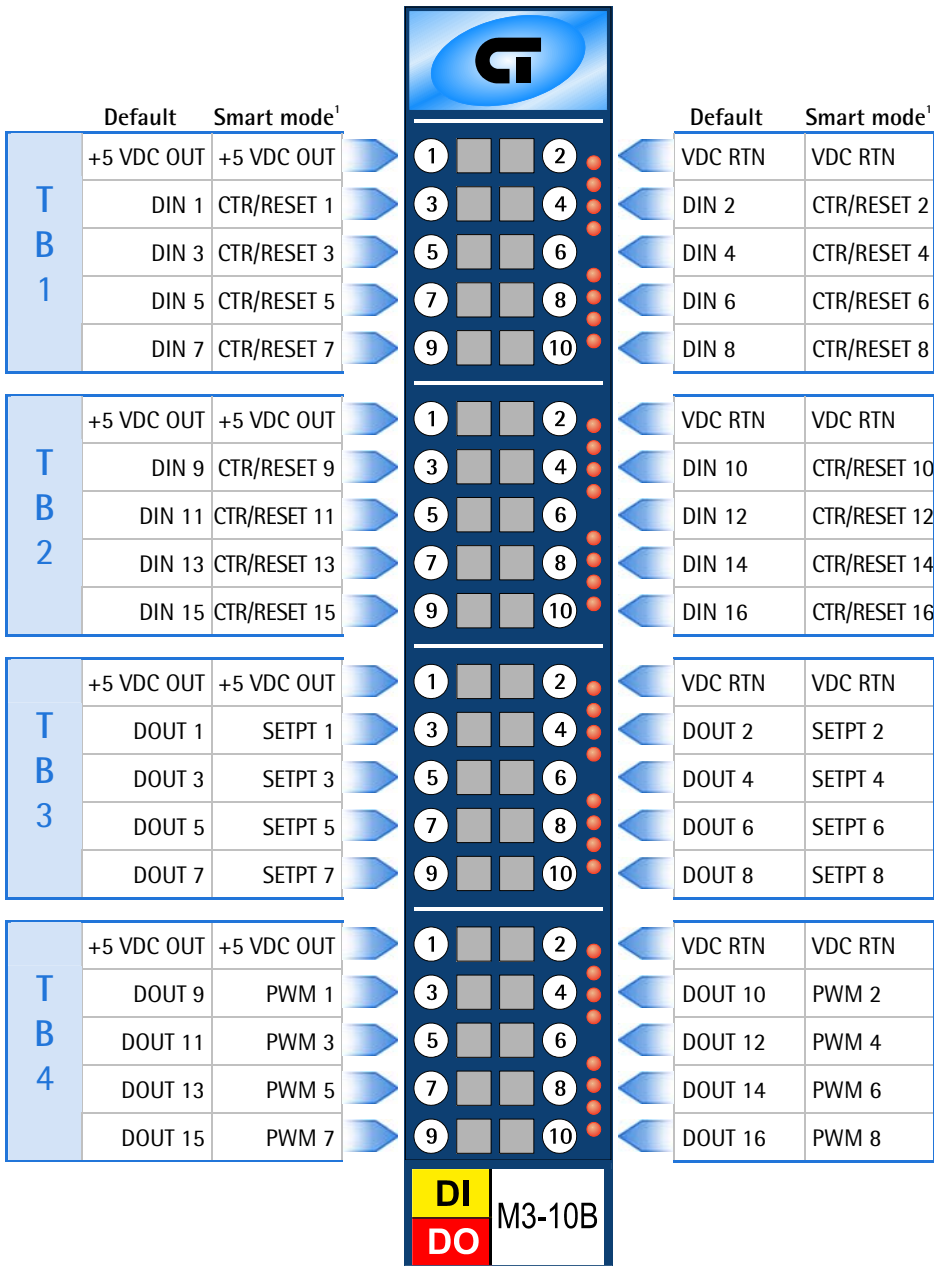

| LED# | Indication |
|------|------------|
| 1    | DI1        |
| 2    | DI2        |
| 3    | DI3        |
| 4    | DI4        |
| 5    | DI5        |
| 6    | DI6        |
| 7    | DI7        |
| 8    | DI8        |

|    |      |
|----|------|
| 9  | DI9  |
| 10 | DI10 |
| 11 | DI11 |
| 12 | DI12 |
| 13 | DI13 |
| 14 | DI14 |
| 15 | DI15 |
| 16 | DI16 |

|    |     |
|----|-----|
| 17 | DO1 |
| 18 | DO2 |
| 19 | DO3 |
| 20 | DO4 |
| 21 | DO5 |
| 22 | DO6 |
| 23 | DO7 |
| 24 | DO8 |

|    |      |
|----|------|
| 25 | DO9  |
| 26 | DO10 |
| 27 | DO11 |
| 28 | DO12 |
| 29 | DO13 |
| 30 | DO14 |
| 31 | DO15 |
| 32 | DO16 |

### Note

- Smart mode is not available on the M3-10B module.
- If TB1 is set up as counters, TB2 will be resets and vice versa.

## Intelligent digital input/output module

DI/O

M3-10B

DI/O

M3-20C

### Application information

#### Typical input application

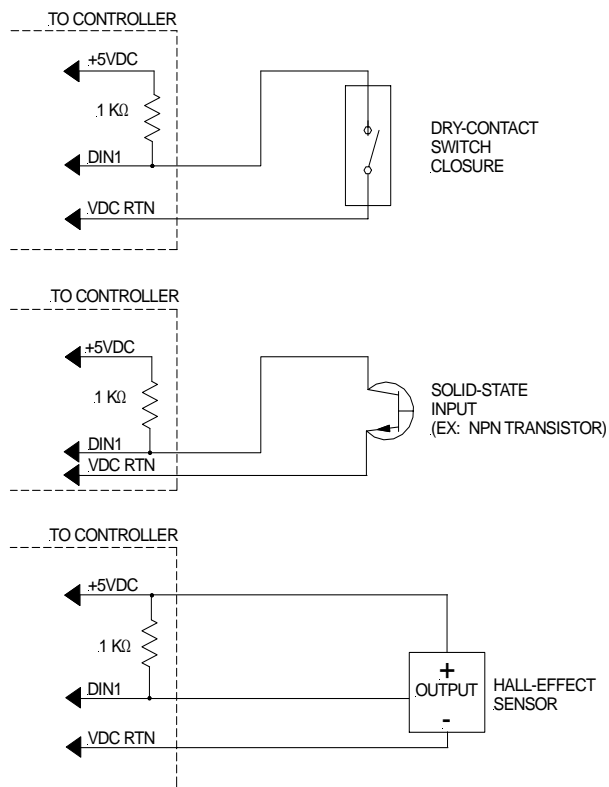

#### Typical output application

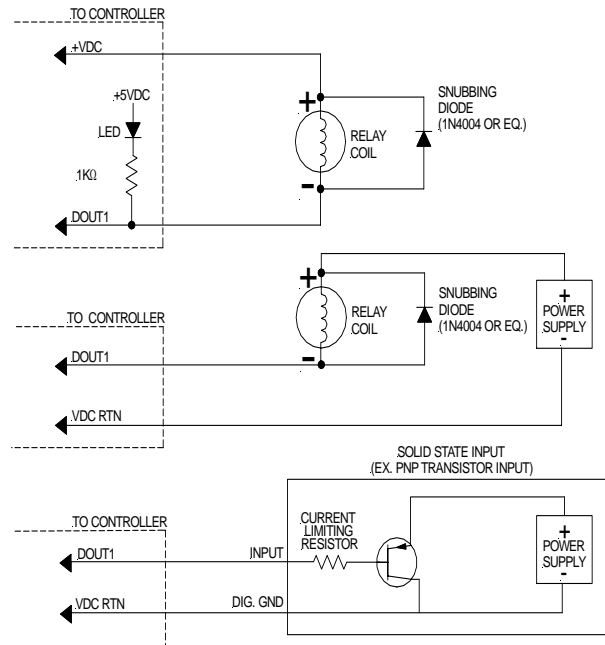

- For applications using externally powered devices (output applications #2 and #3 above), the M3-10B module requires a minimum hardware version of B002 and the M3-20C module requires a minimum hardware version of B001.

#### Notes

- When a digital device is powered via an external power source, it may be necessary to tie the ground of this power source to the controller's voltage supply ground (VDC RTN).
- For register and programming information, refer to the appropriate controller Applications Guide.
- The information and illustrations contained herein are the property of Control Technology Corporation and are subject to change without notice. Data based on  $V_S = 24 \text{ VDC} @ 25^\circ\text{C}$  unless otherwise noted. For additional information and/or updates, visit [www.ctc-control.com](http://www.ctc-control.com).
- Observe proper current limiting with transistor loads.
- Use high-speed diode or equivalent to limit inductive load kicks.
- $VDC \text{ OUT} = V_S(\text{DC voltage supplied to controller's power supply})$ .