

## Digital output module

DO

M3-14A

DO

M3-14B

**M3-14A:** 32 sinking outputs (+VS VDC)

**M3-14B:** 16 sinking outputs (+VS VDC)

- ▶ Open collector NPN transistor to the controller's voltage supply return
- ▶ High current: 500 mA per output/3A per module
- ▶ Individual LED status indicator for each output
- ▶ Optically isolated

### General specifications

Outputs per module:	
M3-14A	32
M3-14B	16
Output type	Sinking (NPN open collector)
Connection	Removable terminal block
Connection type	Tension clamp
Terminal block part number	069-621010
Terminal wire size (UL 1059)	18 - 22 AWG
Test point	All connections
Status indicator	One LED per channel
Module size	1 rack slot (0.75"/19 mm)
Isolation rating	500 VDC
Operating temperature	
Horizontal installation	0 - 50°C
Vertical installation	0 - 45°C
Storage temperature	-25 - 85°C
Humidity	5 - 95% non-condensing

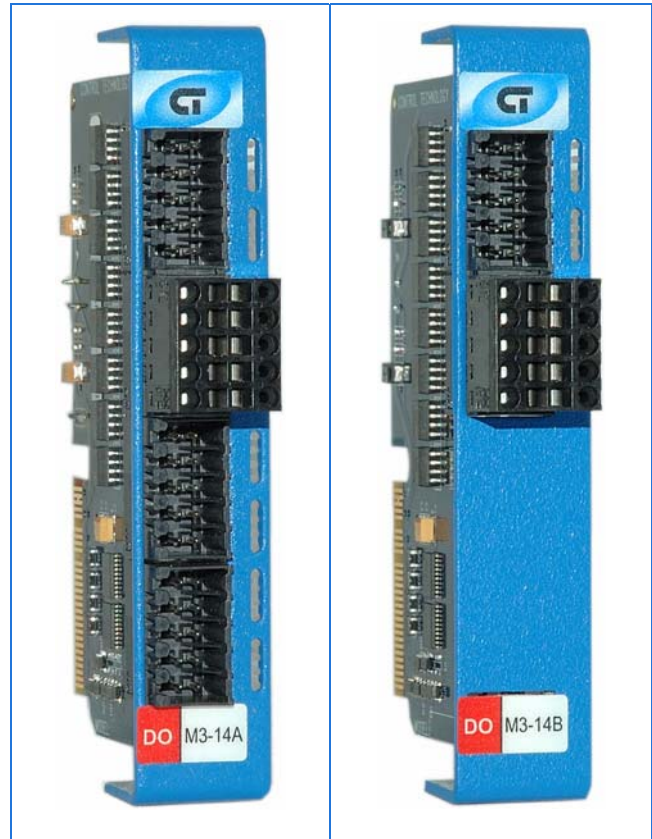

Minimum hardware revision	A
Minimum firmware revision	1.02
Minimum operating system revision	5.00.90
Documentation number: 950-531401-001	

Digital output module	DO	M3-14A
	DO	M3-14B

## Performance specifications

Parameter	Value
Nominal voltage (VN)	VS
Max OFF voltage	Open collector
Max ON voltage @:	
50 mA	0.9 VDC
500 mA	1.4 VDC
Max channel current	500 mA
Max module current	3 ADC
Max controller current	8 ADC
Max leak current/channel	200 $\mu$ ADC

1. In the OFF state, the outputs are pulled internally high to +VS VDC via a 10K $\Omega$  series resistor with an LED.

# Digital output module

DO	M3-14A
DO	M3-14B

M3-14A: 32 sinking outputs (+VS VDC)

M3-14B: 16 sinking outputs (+VS VDC)

## Terminal block connections

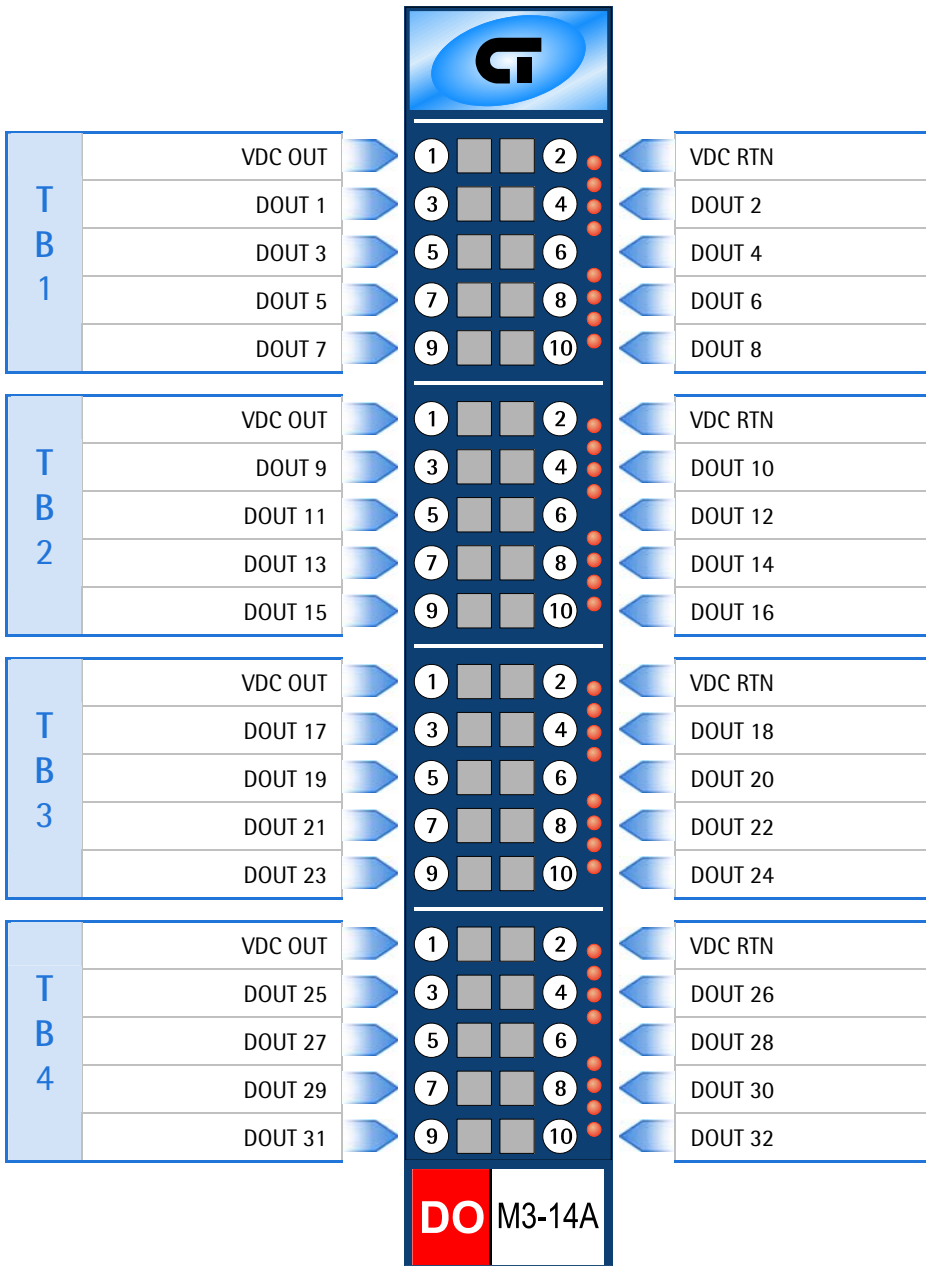

LED#	Indication
1	D01
2	D02
3	D03
4	D04
5	D05
6	D06
7	D07
8	D08

9	D09
10	D010
11	D011
12	D012
13	D013
14	D014
15	D015
16	D016

17	D017
18	D018
19	D019
20	D020
21	D021
22	D022
23	D023
24	D024

25	D025
26	D026
27	D027
28	D028
29	D029
30	D030
31	D031
32	D032

### Note

1. TB3 and TB4 not available on M3-14B.

## Digital output module

DO

M3-14A

DO

M3-14B

### Application information

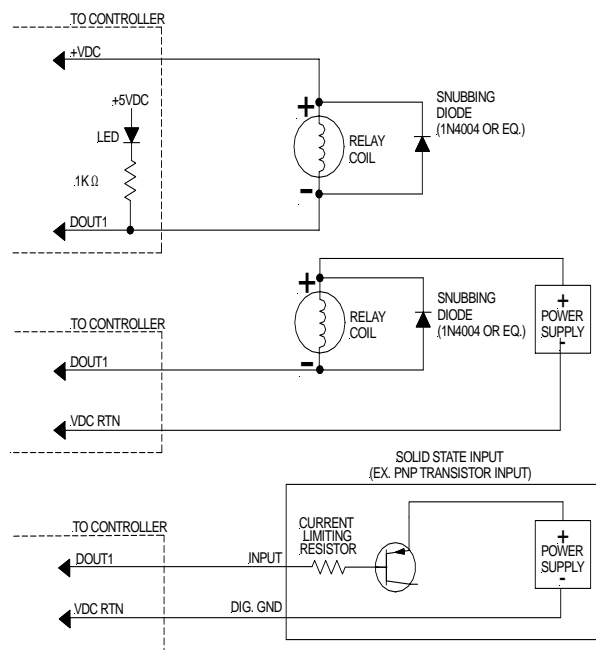

1. For applications using externally powered devices (output applications #2 and #3 above), the M3-14A module requires a minimum hardware version of A006 and the M3-14B module requires a minimum hardware version of A501.

### Notes

1. Observe proper current limiting with transistor loads.
2. Use high-speed diode or equivalent to limit inductive load kicks.
3. When a digital device is powered via an external power source, it may be necessary to tie the ground of this power source to the controller's voltage supply ground (VDC RTN).
4. For register and programming information, refer to the appropriate controller Applications Guide.
5. The information and illustrations contained herein are the property of Control Technology Corporation and are subject to change without notice. Data based on  $V_S = 24 \text{ VDC} @ 25^\circ\text{C}$  unless otherwise noted. For additional information and/or updates, visit [www.ctc-control.com](http://www.ctc-control.com). Copyright © 2007 Control Technology Corporation. All Rights Reserved.