

Three axis stepper/HSC module

MC

M3-40C

3 axis stepper controller and high-speed counter
5V step/dir interface

- ▶ Step rates up to 4 MHz
- ▶ Advanced floating point position loop
- ▶ Encoder rate 17.5 MHz
- ▶ < 1 µsec registration response
- ▶ High-speed, on-board motion processor
- ▶ Closed-loop stepper control (axis A and B only)
- ▶ Optically and electrically isolated
- ▶ 16 inputs configurable as 10 MHz counters
- ▶ 6 position-based outputs

General specifications

Number of axes	3
Axis type	Stepper
Command type	Step/direction
Digital inputs	10
Digital outputs	10
Encoder inputs	2(A, B, Z)
Counter inputs	16 @ 10 MHz
Connection	Removable terminal block
Connection type	Tension clamp
Terminal block part number	069-622210
Terminal wire size (UL 1059)	18 - 22 AWG
Test point	All connections
Status indicator	One LED per channel
Module size	1 rack slot (0.75"/19 mm)
Bus power required (5 VDC)	0.26 mA
Isolation rating	500 VDC
Operating temperature	
Horizontal installation	0 - 50°C
Vertical installation	0 - 35°C
Storage temperature	-25 - 85°C
Humidity	5 - 95% non-condensing



Minimum hardware revision	A
Minimum firmware revision	1.02
Minimum operating system revision	5.00.90
Documentation number: 950-534003-001	

Three axis stepper/HSC module

MC

M3-40C

Performance specifications

Parameter	Value
Position range	64-bit
Position resolution	±1 step
Velocity range	±4M steps/sec
Velocity resolution	±1 step/sec
Position loop update	500 µsec/2 axes
Command resolution	1 step
Closed loop feature	Encoder
Encoder feedback type	5 V - differential quadrature
Max encoder rate	17.5 MHz

Electrical specifications

Parameter	Value
Max encoder input voltage	6 VDC
Encoder Turn ON/OFF threshold	±200mV
Encoder termination resistor	100Ω (10%)
Registration input type	VDC sourcing
Registration response	<1 µsec
Registration Turn ON threshold	0.53 * VS
Registration Turn OFF threshold	0.32 * VS
Max registration voltage	VS
Max ON registration current	2.6 mA DC
Registration input resistance to VDC RTN	10 KΩ (10%)
Output current:	
per channel	±0.5 A
per module	±3 A
per controller	±8 A
Output voltage: ⁴	
V _{ol} (sinking) @ 100 mA	0.4 VDC
V _{ol} (sinking) @ 0.5 A	2 VDC
V _{oh} (sourcing) @ 100 mA	VS - 0.4 VDC
V _{oh} (sourcing) @ 0.5 A	VS - 2 VDC

Additional features

Parameter	Value
Per module motion I/O	
Inputs:	
Assignable ¹	10
Registration ²	4
Capture speed	< .25 µsec
Outputs:	
Assignable ³	10
Move types:	Linear, Cam, Spline, Gear, Segmented moves

Application notes

1. General purpose inputs and outputs can be assigned special functions such as limits, enable, running, etc. or used programmatically. They can also be configured as high-speed (10 MHz) counters. See *Doc. No. 951-530017: QuickMotion Reference Guide* for details.
2. Any two inputs can be configured as high-speed registration inputs (response time < 0.25 µsec).
3. Three pairs of digital outputs can be used for stepper drive control or used as standard outputs.
4. VS for Step/Dir A, B outputs is 5V.

Three axis stepper/HSC module

MC

M3-40C

3 axis stepper controller and high-speed counter
5V step/dir interface

Terminal block connections

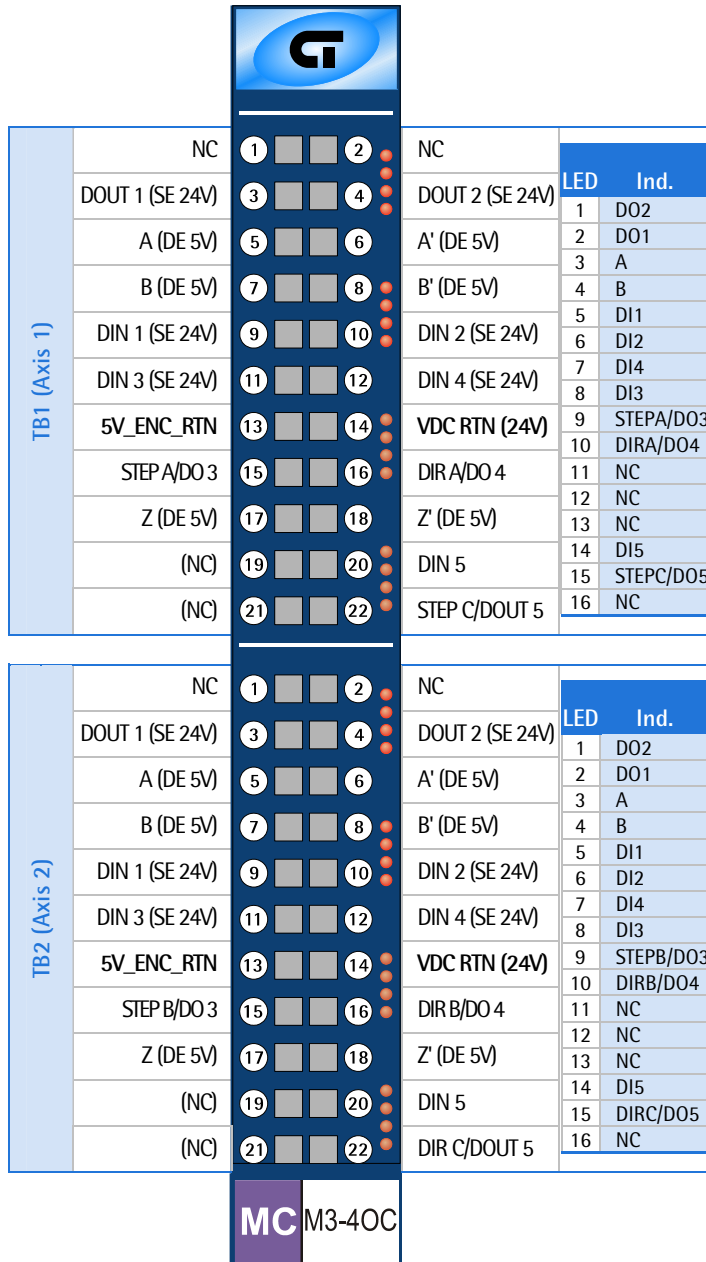

Special I/O Functions

- **16 HS Counters (10 MHz):** All five inputs as well as the A, B, and Z signal pins on each axis connector can be configured as high-speed counters.
- **Period Measurement (0.1 μsec accuracy):** Two pairs of inputs on each axis can be set up to measure the time between activation of the first and second input in the pair. Ideal for high-speed measurement and frequency measurement.
- **Frequency Outputs:** Three outputs on each axis can generate a programmable frequency up to 500 KHz.
- **Pulse Outputs:** All ten outputs can be pulsed for a programmable time value with an accuracy of 0.5 msec.
- **Programmable Limit Switch Outputs:** Three outputs on each axis can be configured to automatically turn on and off as a function of the encoder position. Up to sixteen on/off positions can be configured per axis. The on/off positions can be changed programmatically on-the-fly. This is especially useful to compensate for lead or lag time based on operating speed.

1. Step A/B and Dir A/B connections are single-ended 5V. Step/Dir C connections are single-ended 24V.

Three axis stepper/HSC module

MC

M3-40C

Application Information

Differential Encoder/Counter Application

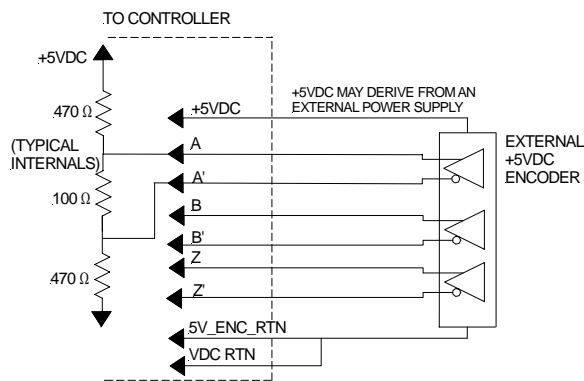

All Single-ended Inputs Application

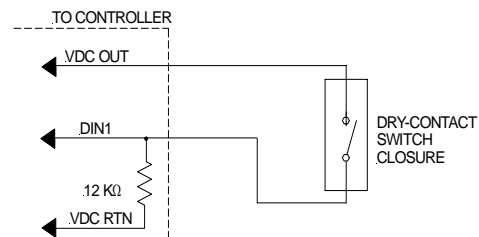

Digital Outputs & Stepper Command

Sourcing

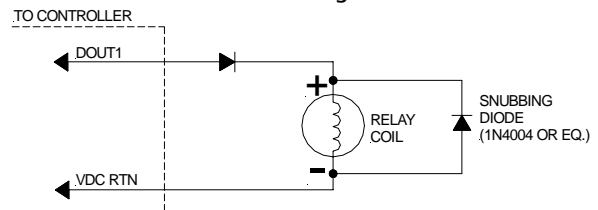

Notes

1. If an output is used to drive transistor loads, proper current limiting must be observed.
2. When a digital device is powered via an external power source, it may be necessary to tie the ground of this power source to the controller's voltage supply return (VDC RTN)
3. For register and programming information, refer to the appropriate controller Applications Guide.
4. The information and illustrations contained herein are the property of Control Technology Corporation and are subject to change without notice. Data based on VS = 24 VDC @ 25°C unless otherwise noted. For additional information and/or updates, visit www.ctc-control.com. Copyright © 2007 Control Technology Corporation. All Rights Reserved.
5. VS refers to the voltage supply of the controller.
6. For single-ended counter or encoder input signals, tie A', B', and Z' to 5V_ENC_RTN.