



25 South Street  
Hopkinton, MA 01748  
Phone: 508.435.9595  
Fax: 508.435.2373  
[www.ctc-control.com](http://www.ctc-control.com)

# Data Sheet

## 5100-G Analog Input Module

### Four $\pm 20$ mVDC Analog Inputs

AI	$\pm 20$ mVDC	G
4 Analog Inputs		

Data Sheet: 5100-G Analog Input Module

### Description

- ▶ Four 13-bit,  $\pm 20$  mVDC bipolar analog inputs
- ▶ Three differential-ended inputs and one single-ended input
- ▶ Analog input circuitry is electrically isolated.
- ▶ On-board input averaging, 64 samples per digital input

### 5100-G Specifications

Parameter	Value	Description
<b>General</b>		
Number of inputs	4	Three differential-ended inputs and one single-ended input
Connection type	Screw terminal	Screw terminal spring clamp accepts #14-22 AWG wire. Terminated connector may also be unplugged.
Input type	$\pm 20$ mVDC	
Resolution	13-bit	1 in 8192 counts; 4.88 $\mu$ V/LSB
Engineering units (Channel Configurable)	$\pm 20,000$ $\pm 10,000$ $\pm 10,000,000$	Integer numbers used by the 5100 to represent an input value. +20,000 mVDC = 20,000 ( $\pm 99,999,999$ = over/under range) +20,000 mVDC = 10,000 (Default) 20,000 mVDC = 10,000,000
Signal type Analog inputs #1-3 Analog input #4	Diff.-ended Single-ended	The input reading is the current difference between +AINx and -AINx. One input terminal is referenced to analog common (ACOM).
Common mode voltage	$\pm 15$ VDC	The maximum input voltage in reference to analog common (ACOM).
Isolation rating	500 VDC	Isolation voltage between any input and other sensitive 5100 circuitry.
Input protection	$\pm 40$ VDC	Absolute maximum input voltage
Input impedance: +Ain to -Ain +Ain to ACOM - Ain to ACOM (Ain#1-3)	$10^{12} \Omega$ $10^{12} \Omega$ $1.5M\Omega$	The impedance between the positive and negative inputs. The impedance between the input and analog common. The impedance between the positive input and analog common.
+5 VDC supply current	0.2 mA	Current requirements from the 5100's +5 VDC power supply.
Model type	5131	Identifier for the hardware and software type
<b>Performance</b>		
Full scale calibration error Ta=25°C Ta=Full range	$\pm 2$ LSB $\pm 4$ LSB	The error between the measured input voltage and a true +10.000000 VDC.
Offset calibration error Ta=25°C Ta=Full range	$\pm 2$ LSB $\pm 4$ LSB	The error between the measured input voltage and a true 0.000000 VDC.
Integral linearity error Ta=25°C Ta=Full range	$\pm 3$ LSB $\pm 6$ LSB	The maximum error in the measured input voltage across the entire input range.
Digital input filter size	64 samples	The number of samples used in an input's average calculation.
Filter sample rate	400 $\mu$ Sec	The rate at which all analog input channels are sampled.
<b>Environmental</b>		
Temperature Operating Storage	0 to 50°C -25 to 85°C	Refer to the 5100 Controller Data Sheet for proper mounting instructions.

### Application Information

#### Typical Application

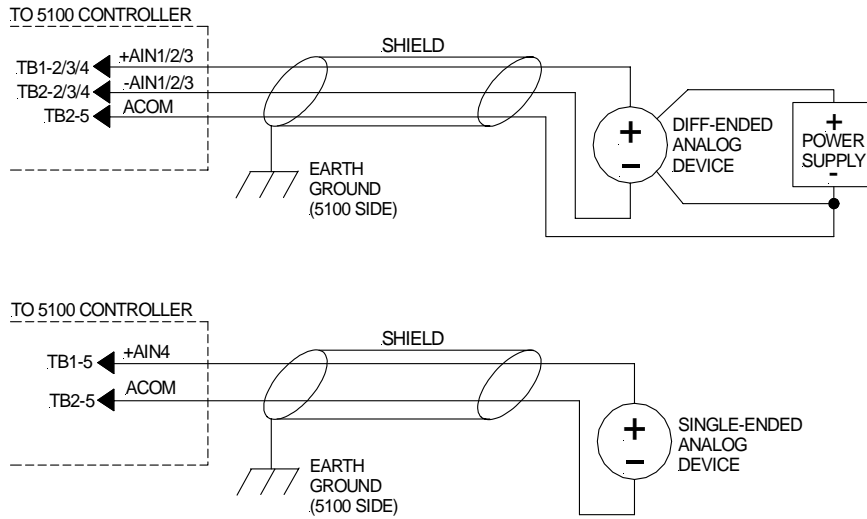

### Module Identification

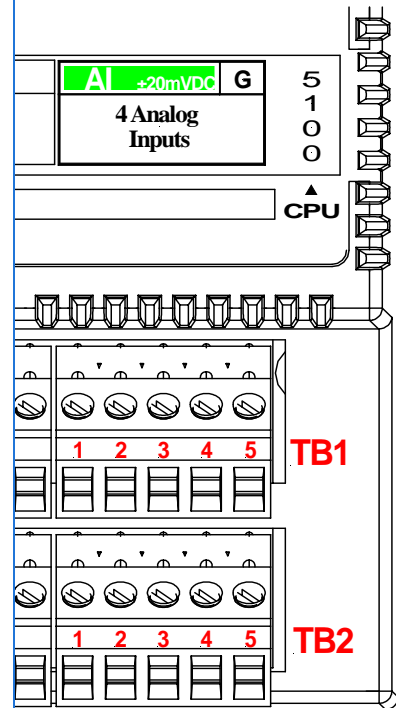

#### I/O Terminations

TB1-1	VS_OUT
TB1-2	+Ain #1
TB1-3	+Ain #2
TB1-4	+Ain #3
TB1-5	+Ain #4 (S.E.)
TB2-1	VS_RTN
TB2-2	-Ain #1
TB2-3	-Ain #2
TB2-4	-Ain #3
TB2-5	ACOM

#### Notes



- Shield grounds must be terminated on the 5100-controller side of the cable.
- When an analog device is powered via an external power source, it may be necessary to tie the ground of this power source to the module's analog common (ACOM) to limit common mode voltages.
- For register and programming information, refer to the Model 5100 Applications Guide.
- VS refers to the voltage supply of the controller.

The information in this document is subject to change without notice. Any software described in this document is provided under license agreement and may be used or copied only in accordance with the terms of the license agreement.

The information, drawings, and illustrations contained herein are the property of Control Technology Corporation. No part of this manual may be reproduced or distributed by any means, electronic or mechanical, for any purpose other than the purchaser's personal use, without the express written consent of Control Technology Corporation.